

E-Z TRENCH[®]

EZ-9100 GRINDSAW[™]

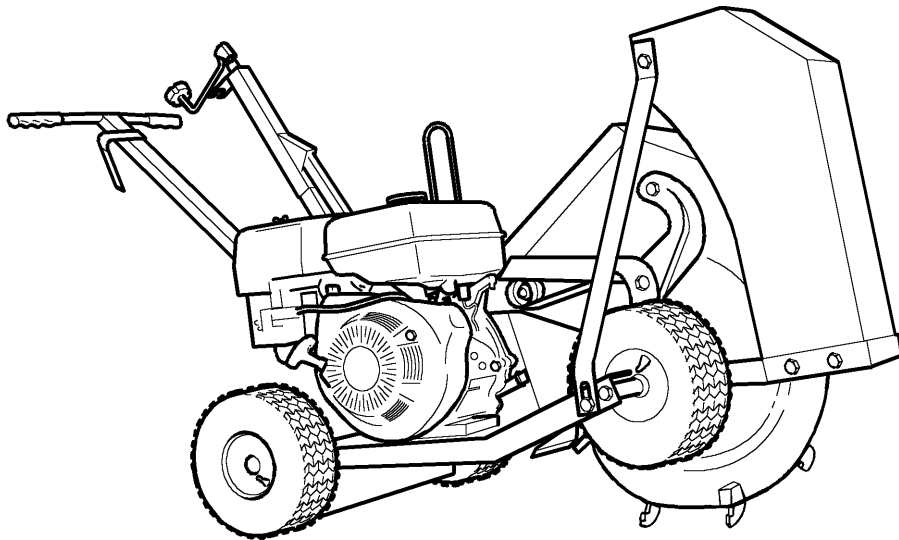

Owners Manual

E-Z Trench Manufacturing Co., Inc.

2315 S. Hwy. 701 • Loris, S.C. 29569

(843) 756-6444

Fax (843) 756-6442

www.eztrench.com

A WORD TO E-Z TRENCH OWNERS . . .

THIS MANUAL HAS BEEN PREPARED TO ACQUAINT YOU WITH THE ASSEMBLY, OPERATION AND MAINTENANCE OF YOUR E-Z TRENCH TRENCHING MACHINE, AND TO PROVIDE SAFETY INFORMATION. WE URGE YOU TO READ IT CAREFULLY AND FOLLOW THE RECOMMENDATIONS CONTAINED TO HELP ASSURE THE MOST TROUBLE-FREE OPERATION.

WE WOULD LIKE TO TAKE THIS OPPORTUNITY TO THANK YOU FOR CHOOSING E-Z TRENCH, AND TO ASSURE YOU OF OUR CONTINUING INTEREST IN YOUR NEEDS.

INDEX

1. A WORD TO E-Z TRENCH OWNERS & SAFETY PRECAUTIONS
2. OPERATING INSTRUCTIONS.
3. MAINTENANCE SCHEDULE
- 4-5. PARTS DRAWING / PARTS LIST
6. TERMS AND WARRANTY
7. WARRANTY REGISTRATION
8. TROUBLE SHOOTING & BOLT SIZES.

WARNINGS! & SAFETY PRECAUTIONS

1. ALWAYS WEAR EYE PROTECTION.
2. STAY CLEAR FROM CUTTING BLADES.
3. KEEP HANDS AND FEET CLEAR OF PULLEYS AND BELTS WHEN ENGINE IS RUNNING.
4. LOCATE ALL UNDERGROUND POWER LINES, GAS LINES, AND WATER LINES BEFORE TRENCHING.
5. ENGINE R.P.M. SHOULD RUN AT 3600 R.P.M.

EZ9100 OPERATING INSTRUCTIONS

1. FILL CRANKCASE AND CLUTCH WITH OIL BEFORE STARTING. FOLLOW INSTRUCTIONS OF ENGINE MANUFACTURER.
2. START ENGINE.
3. SQUEEZE THROTTLE LEVER ON HANDLE BAR TO START BLADE.
4. SLOWLY LOWER THE BLADE BY TURNING DEPTH ADJUSTMENT CRANK (8012) CLOCKWISE UNTIL DESIRED DEPTH IS REACHED.
5. PULL THE MACHINE BACKWARD. BEGIN TRENCHING SLOWLY UNTIL FAMILIAR WITH THE MACHINE AND SOIL CONDITIONS.
6. IF THE BLADE STOPS TURNING WHILE TRENCHING, THE CLUTCH IS SLIPPING DUE TO TRENCHING TOO FAST OR SUDDEN IMPACT WITH AN OBJECT. STOP TRENCHING AND REMOVE OBJECT FROM PATH OR SLOW DOWN. THEN CONTINUE TRENCHING.

**AFTER MACHINE HAS RUN APPROXIMATELY ONE HOUR:
RE-ADJUST CHAIN IN GEAR BOX BY SLIDING GEAR BOX DOWN.
THIS IS DONE BY LOOSENING THE THREE BOLTS BEHIND THE
PULLEY (EZ40) AND SLIDING THE GEAR BOX AWAY FROM THE
HANDLE BAR, THEN RETIGHTENING THE BOLTS.**

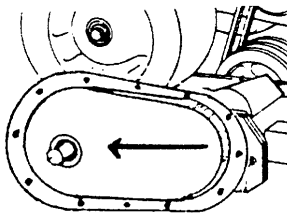

2.

EZ9100 GROUNDSAWE™ MAINTENANCE SCHEDULE

Perform at every indicated month or operating hour interval, whichever comes first.	Every Use	First month or 20 Hrs.	Every 3 months or 50 Hrs.	Every 6 months or 100 Hrs.
Check blade and bits*	○			
Check engine oil & air filter	○			
Lubricate pivot points after washing	○			
Snug castle nut on top of jack		○		○
Tighten any loose bolts		○		
Change engine oil**		○	○	
Tighten chain in gearbox (pg 2)			○	
Check air pressure of tires			○	
Clean air filter or replace			○	
Change clutch oil***		○	○	

*Replace carbide bits before carbide tips are completely worn.

See tips below on proper bit installation.

**Break in engine with petroleum based oil, then switch to E-Z Trench™ specially formulated synthetic.

***Use only E-Z Trench™ synthetic for high wear resistance and reduced heat.

MAINTENANCE TIPS

1. DO NOT OVERTIGHTEN NUT ON BACKSIDE OF LARGE PULLEY (EZ40). IT ONLY NEEDS TO BE SNUG.
2. KEEP CASTLE NUT ON TOP OF JACK SNUG.
3. TO REPLACE BITS:
 - A. INSERT 2 STRAIGHT BITS DIRECTLY ACROSS FROM EACH OTHER.
 - B. NEXT, INSERT THE LEFT AND RIGHT BITS BY PLACING THEM IN THE SLOT THAT BENDS IN THE SAME DIRECTION AS THE BIT. (REMEMBER THAT THE CARBIDE SHOULD FACE LEFT WHEN YOU ARE FACING THE MACHINE FROM THE BLADE SIDE.)
4. NOTE: PROPER BELT TENSION, 1/8" OR WHEN A DIME WILL FIT SNUGLY BETWEEN COIL SPRING.

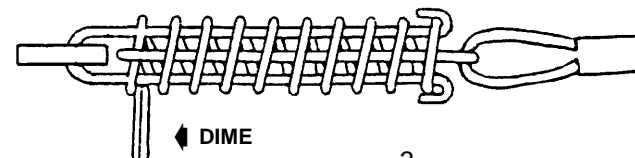

3.

PARTS# DESCRIPTON

8012	DEPTH ADJUSTMENT CRANK
8013	DEPTH LINKAGE ROD
8013A	JACK LINKAGE BUSHING
8014	DEPTH CONTROL SCREW
8014A	CASTLE NUT
8014B	BRASS BUSHING
8014C	JACK SHIM
8015	LINKAGE PIN
8016	1/4 X 2 X 5" WASHER PLATE
8048	COMPLETE JACK
8048A	JACK BOTTOM
8048B	JACK TOP
8160	HANDLE
9002	HOOD
9003	PNEUMATIC WHEEL
9004	PUSH CAP
9017	BLADE GUARD
9018	BELT GUARD
9027	INSIDE HALF GEAR BOX
9029	SPACER BUSHING
9030	11 TOOTH SPROCKET
9033	CHAIN
9038	HOOD BRACE
9045	BEARING (INSIDE GEARBOX HALF)
9022V4	1" BEARING
9028V4	OUTSIDE HALF GEARBOX
9031V4	29 TOOTH SPROCKET
9032V4	1" SHIM
9034V4	1" NUT
9035V4	HD BLADE ASMBLY W/OUT BITS
9036A	ROLL PINS
9036L	LEFT HEAVY DUTY CARBIDE BIT
9036R	RIGHT HEAVY DUTY CARBIDE BIT
9036ST	STRAIGHT HEAVY DUTY CARBIDE BIT
9039	FRONT AXLE
9039A	FRONT AXLE SPACER
9049V4	BLADE W/BITS (1" ARBOR)
9100	FRAME
9100A	DEBRIS DEFLECTOR
9100B	GREASE FITTING
9142	ENGINE PULLEY
9142A	CRANKSHAFT EXTENSION
9142B	CRANKSHAFT SPACER
9142C	CRANKSHAFT KEY
EZ1	ENGINE THROTTLE
EZ10	BELT TENSION SPRING
EZ11	TENSIONER EYE BOLT
EZ16	HANDLE GRIPS
EZ2	THROTTLE CABLE
EZ22	3/4" BEARING
EZ380	3/4" NUT
EZ40	LARGE PULLEY
EZ43	IDLER ASSEMBLY
EZ6835	BELTS
EZ70	V-IDLER PULLEY
EZ90	HALF MOON KEY

TERMS AND CONDITIONS OF SALE**USE:**

E-Z TRENCHER IS DESIGNED TO TRENCH IN SOIL ONLY. ANY OTHER USE IS AT THE RISK OF THE OWNER.

PRICES:

Prices are subject to change without notice and will be invoiced at prices in effect on date of order.

CHANGES:

E-Z TRENCH MANUFACTURING, Inc. reserves the right to discontinue items, change specification, design, or prices at any time, without notice and without incurring any obligation whatsoever.

FREIGHT POLICY:

All orders are F.O.B., Loris, South Carolina, USA. Title to goods and risk of loss passed in Loris, South Carolina.

DAMAGED OR LOST SHIPMENTS:

All shipments must be carefully inspected. In case of damaged or loss, accept the shipment, but have carrier note damages or loss on delivery receipt. If it is concealed damage, call carrier for inspection. Make claim for damage with carrier.

LIMITED WARRANTY:

The E-Z Trencher is warranted against defects in workmanship or materials for a period of one year. Blades, bits, belts, clutches and bearings, which are normal wear items, are not warranted. This warranty covers replacement of parts only, no consequential damages are covered. In the event of a warranty claim contact E-Z Trench Manufacturing Company, Inc. This warranty does not include products which have been subject to improper use, or application, or misuse, neglect or accident; nor does it attend to products which have been repaired or altered by other than E-Z Trench Manufacturing Company, Inc. All warranty repairs are F.O.B., Loris, S.C, U.S.A. E-Z Trench Manufacturing Company, Inc. will not be responsible for any transportation charges.

THERE IS NO OTHER EXPRESS WARRANTY. TO THE EXTENT PERMITTED BY LAW ALL IMPLIED WARRANTIES INCLUDED THOSE OF MERCHANTABILITY AND FITNESS FOR A PARTICULAR PURPOSE ARE EXCLUDED. LIABILITY FOR CONSEQUENTIAL DAMAGES UNDER ANY AND ALL WARRANTIES ARE EXCLUDED TO THE EXTENT THAT EXCLUSION IS PERMITTED BY LAW. Some states do not allow limitation on how long an implied warranty lasts, and some

states do not allow the exclusion or limitation or incidental or consequential damages, so the above limitation and exclusion may not apply to you. This warranty gives you specific legal rights and you may also have other rights which may vary from state to state.

E-Z Trench Manufacturing Company, Inc. does not warrant the engine but the purchaser must look to the engine manufacturer for the warranty of the engine.

NORMAL WEAR:

Warranty will not cover repair where normal use has exhausted the life of a part. Trenchers, like all mechanical devices, need periodic parts replacement and service to perform well. It should be remembered that the service life of any trencher is dependent on the care it receives and the conditions under which it has to operate. Trenchers operate in harsh conditions, which can cause what appears to be premature wear. Such wear, when caused by rocks or other abrasive material, is not covered by warranty.

E-Z TRENCH WARRANTY DOES NOT COVER THE FOLLOWING:

1. Bent or broken parts; Such damage is normally the result of abuse, such as striking a solid object with the cutting blade.
2. Broken parts, which results from excessive vibration caused by loose engine mounting, loose cutting blades, unbalanced blades, improperly attaching equipment to trencher, overspeeding or abuse in operation.
3. Misuse, neglect, improper operation, damage or abuse.
4. Alteration or removal of name plates or serial numbers.
5. Modification or change of this product outside the factory.

STANDARD TERMS:

1. C.O.D./F.O.B., Loris, SC, USA
2. Cash, money order, certified check, or wire transfer with order.
3. 30 day with approved credit.

All sales are final with no right to return, price protection or implied consignment. No person, including agent, representative, or employee of E-Z TRENCH MANUFACTURING, Inc. is authorized to assume for E-Z TRENCH MANUFACTURING, Inc. any obligation or liability concerning terms or conditions of sale other than that expressly stated herein.

EFFECTIVE MARCH 1, 1985

TROUBLE SHOOTING

<u>PROBLEM</u>	<u>SOLUTION</u>
IRREGULAR OR EXCESSIVE BELT WEAR	<ol style="list-style-type: none"> 1. CHECK FOR PULLEY MISALIGNMENT. 2. USE OF OTHER THAN FACTORY POWER-RATED BELTS. 3. RATE OF DIG IS TOO FAST FOR SOIL CONDITION.
EXCESSIVE VIBRATION	<ol style="list-style-type: none"> 1. LOOSE, BENT, OR BROKEN BLADE OR BIT. 2. LOOSE ENGINE MOUNT BOLTS. 3. ENGINE R.P.M. SHOULD BE 3600 R.P.M.
HOUSING CLOGGING WITH DIRT	<ol style="list-style-type: none"> 1. SOIL IS TOO WET. 2. FOREIGN OBJECT IN HOUSING.
BENT OR BROKEN DIGGING BLADE	<ol style="list-style-type: none"> 1. STRIKING HARD OBJECTS, SUCH AS BRICKS, LARGE ROCKS, AND STEEL OBJECTS.

BOLT SIZES FOR EZ9100 GROUNDSAW™

<u>PART #</u>	<u>QTY.</u>	<u>SIZE</u>	<u>ATTACHES PART...</u>
516134	2	5/16 x 1 3/4	8160 to frame
14234	1	1/4 x 2 3/4	8048A
382	1	3/8 x 2	8048B to 8013
38214	1	3/8 x 2 1/4	8048A to 9101
516134	4	5/16 x 1 3/4	engine bolts
38134	1	3/8 x 1 3/4	EZ43
38112	1	3/8 x 1 1/2	EZ70 to EZ43
51612C	2	5/16 x 1/2	9018
51634	6	5/16 x 3/4	9002
51634	1	5/16 x 3/4	9038 to frame
5161	3	5/16 x 1	9017 to frame & 9038
1458	12	1/4 x 5/8	9027 and 9028V4
3858G8	3	3/8 x 5/8	transfer case to carriage
14114	1	1/4 x 1 1/4	8012 to 8014
14516ss	2	1/4 x 5/16	set screws for large pulley
51638ss	2	5/16 x 3/8	set screws for engine pulley